



# **Installing a Dialogic® TX 4000 PCI SS7 Network Interface Board**

September 2010      64-0430-04 Rev A

---

[www.dialogic.com](http://www.dialogic.com)

## Copyright and legal notices

Copyright © 2007-2010 Dialogic Corporation. All Rights Reserved. You may not reproduce this document in whole or in part without permission in writing from Dialogic Corporation at the address provided below.

All contents of this document are furnished for informational use only and are subject to change without notice and do not represent a commitment on the part of Dialogic Corporation or its subsidiaries ("Dialogic"). Reasonable effort is made to ensure the accuracy of the information contained in the document. However, Dialogic does not warrant the accuracy of this information and cannot accept responsibility for errors, inaccuracies or omissions that may be contained in this document.

INFORMATION IN THIS DOCUMENT IS PROVIDED IN CONNECTION WITH DIALOGIC® PRODUCTS. NO LICENSE, EXPRESS OR IMPLIED, BY ESTOPPEL OR OTHERWISE, TO ANY INTELLECTUAL PROPERTY RIGHTS IS GRANTED BY THIS DOCUMENT. EXCEPT AS PROVIDED IN A SIGNED AGREEMENT BETWEEN YOU AND DIALOGIC, DIALOGIC ASSUMES NO LIABILITY WHATSOEVER, AND DIALOGIC DISCLAIMS ANY EXPRESS OR IMPLIED WARRANTY, RELATING TO SALE AND/OR USE OF DIALOGIC PRODUCTS INCLUDING LIABILITY OR WARRANTIES RELATING TO FITNESS FOR A PARTICULAR PURPOSE, MERCHANTABILITY, OR INFRINGEMENT OF ANY INTELLECTUAL PROPERTY RIGHT OF A THIRD PARTY.

Dialogic products are not intended for use in medical, life saving, life sustaining, critical control or safety systems, or in nuclear facility applications.

Due to differing national regulations and approval requirements, certain Dialogic products may be suitable for use only in specific countries, and thus may not function properly in other countries. You are responsible for ensuring that your use of such products occurs only in the countries where such use is suitable. For information on specific products, contact Dialogic Corporation at the address indicated below or on the web at [www.dialogic.com](http://www.dialogic.com).

It is possible that the use or implementation of any one of the concepts, applications, or ideas described in this document, in marketing collateral produced by or on web pages maintained by Dialogic may infringe one or more patents or other intellectual property rights owned by third parties. Dialogic does not provide any intellectual property licenses with the sale of Dialogic products other than a license to use such product in accordance with intellectual property owned or validly licensed by Dialogic and no such licenses are provided except pursuant to a signed agreement with Dialogic. More detailed information about such intellectual property is available from Dialogic's legal department at 9800 Cavendish Blvd., 5th Floor, Montreal, Quebec, Canada H4M 2V9. Dialogic encourages all users of its products to procure all necessary intellectual property licenses required to implement any concepts or applications and does not condone or encourage any intellectual property infringement and disclaims any responsibility related thereto. These intellectual property licenses may differ from country to country and it is the responsibility of those who develop the concepts or applications to be aware of and comply with different national license requirements.

Any use case(s) shown and/or described herein represent one or more examples of the various ways, scenarios or environments in which Dialogic® products can be used. Such use case(s) are non-limiting and do not represent recommendations of Dialogic as to whether or how to use Dialogic products.

Dialogic, Dialogic Pro, Brooktrout, Diva, Cantata, SnowShore, Eicon, Eicon Networks, NMS Communications, NMS (stylized), Eiconcard, SIPcontrol, Diva ISDN, TruFax, Exnet, EXS, SwitchKit, N20, Making Innovation Thrive, Connecting to Growth, Video is the New Voice, Fusion, Vision, PacketMedia, NaturalAccess, NaturalCallControl, NaturalConference, NaturalFax and Shiva, among others as well as related logos, are either registered trademarks or trademarks of Dialogic Corporation or its subsidiaries. Dialogic's trademarks may be used publicly only with permission from Dialogic. Such permission may only be granted by Dialogic's legal department at 9800 Cavendish Blvd., 5th Floor, Montreal, Quebec, Canada H4M 2V9. Any authorized use of Dialogic's trademarks will be subject to full respect of the trademark guidelines published by Dialogic from time to time and any use of Dialogic's trademarks requires proper acknowledgement.

The names of actual companies and product mentioned herein are the trademarks of their respective owners.

This document discusses one or more open source products, systems and/or releases. Dialogic is not responsible for your decision to use open source in connection with Dialogic products (including without limitation those referred to herein), nor is Dialogic responsible for any present or future effects such usage might have, including without limitation effects on your products, your business, or your intellectual property rights.

**Revision history**

<b>Revision</b>	<b>Release date</b>	<b>Notes</b>
9000-62363-10	September 2003	SRR, SS7 4.0 Beta
9000-62363-11	May 2004	SRR, SS7 4.0
9000-62363-12	August 2004	SRR, SS7 4.1
9000-62363-13	April 2005	LBG
9000-62363-14	July 2008	LBG, SS7 5.0
64-0430-01	July 2009	LBG, SS7 5.1
64-0430-02	May 2010	LBG
64-0430-03	July 2010	LBG
64-0430-04 Rev A	September 2010	LBG
Last modified: September 9, 2010		

Refer to [www.dialogic.com](http://www.dialogic.com) for product updates and for information about support policies, warranty information, and service offerings.

## Table of Contents

Table of Contents .....	4
Introduction .....	5
Configuring the hardware .....	6
Installing the board .....	8
Assigning a CP number .....	9
Establishing network connections .....	10
Connecting TX boards for redundancy .....	13
Interface status LEDs .....	16
Board status LEDs .....	17
Compliance statements .....	18
Europe .....	19
Australia .....	22
South Korea .....	23
China .....	24
Product declarations and global approvals .....	26
RoHS Statement .....	26
Product environmental information .....	26
Limited warranty .....	26

## Introduction

The Dialogic® TX 4000 PCI SS7 Network Interface Board provides four T1 or E1 digital trunk interfaces and two Ethernet 10/100Base-T interfaces. For more information, refer to the *Dialogic® TX 4000 PCI SS7 Network Interface Board Installation Manual* available on [www.dialogic.com](http://www.dialogic.com).

**Note:** The product(s) to which this document pertains is/are among those sold by NMS Communications Corporation (“NMS”) to Dialogic Corporation (“Dialogic”) in December 2008. Certain terminology relating to the product(s) has been changed, whereas other terminology has been retained for consistency and ease of reference. For the changed terminology relating to the product(s), below is a table indicating the “New Terminology” and the “Former Terminology”. The respective terminologies can be equated to each other to the extent that either/both appear within this document.

Former terminology	Current terminology
NMS SS7	Dialogic® NaturalAccess™ Signaling Software
Natural Access	Dialogic® NaturalAccess™ Software

The following table summarizes the steps for installing the TX 4000 hardware and software components:

Step	Description	For details, refer to...
1	<p>Ensure that your system meets the system requirements.</p> <p><b>Note:</b> The TX 4000 board requires a high current from the 3.3 V power supply.</p> <p>The board has the following power requirements:</p> <ul style="list-style-type: none"> <li>• 6.5 A maximum @ 3.3 V</li> <li>• 0.5 A maximum @ 5.0 V</li> <li>• 0.1 A maximum @ 12.0 V</li> </ul>	<i>Dialogic® TX 4000 PCI SS7 Network Interface Board Installation Manual</i>
2	Power down the system if it is running.	
3	Configure the TX 4000 board to enable H.100 bus termination, if applicable.	<i>Configuring the hardware</i> on page 6
4	Configure the TX 4000 board to enable monitor mode, if applicable.	<i>Configuring the hardware</i> on page 6
5	Install the TX 4000 board into one of the computer's PCI bus slots.	<i>Installing the board</i> on page 8
6	Power up the system.	
7	Install the NaturalAccess software.	The <i>Natural Access Installation</i> booklet and <i>Natural Access Developer's Reference Manual</i>
8	Install the Dialogic® NaturalAccess™ Signaling Software.	The <i>Installing Dialogic® NaturalAccess™ Signaling Software</i> and <i>Dialogic® NaturalAccess™ Signaling Software Configuration Manual</i>
9	Assign a CP number for each TX 4000 board.	<i>Assigning a CP number</i> on page 9
10	Connect the board interfaces to T1 or E1 trunks.	<i>Establishing network connections</i> on page 10

Step	Description	For details, refer to...
11	If applicable, connect the Ethernet interfaces for board redundancy, to a SIGTRAN network, or both.	<i>Connecting TX boards for redundancy on page 13</i>
12	Verify that the TX 4000 board is operational.	<i>Interface status LEDs on page 16</i> <i>Board status LEDs on page 17</i>

## Configuring the hardware

Before installing the TX 4000 board, use the following procedures to configure H.100 bus termination and monitor mode if applicable.

<b>Caution:</b>	The TX 4000 board is shipped in a protective anti-static container. Leave the board in its container until you are ready to install it. Handle the board carefully and hold it only by its edges. We recommend that you wear an anti-static wrist strap connected to a good earth ground whenever you handle the board. Take care not to touch the gold fingers that plug into the PCI bus connectors.
-----------------	--

### Configuring H.100 bus termination

The TX 4000 board connects to an H.100 bus. Boards on the H.100 bus are connected to one another with an H.100 bus cable. Enable bus termination on the board located on each end of the H.100 bus:

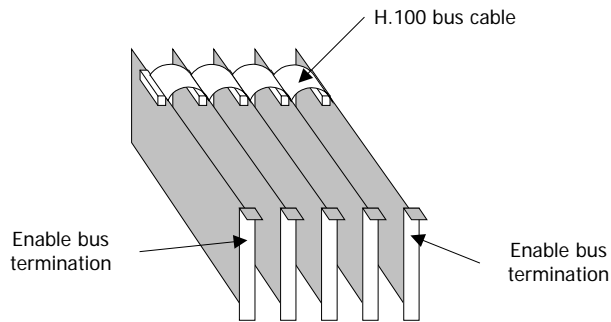

DIP switch S2 on the TX 4000 board controls the H.100 bus termination. By default, all S2 switches are set to the OFF position. H.100 bus termination is disabled. To enable H.100 bus termination, set all S2 switches to the ON position only for the boards that are on the ends of the H.100 bus.

The following illustration shows the default settings for the TX 4000 DIP switches (H.100 bus termination and SS7 Monitor mode disabled):

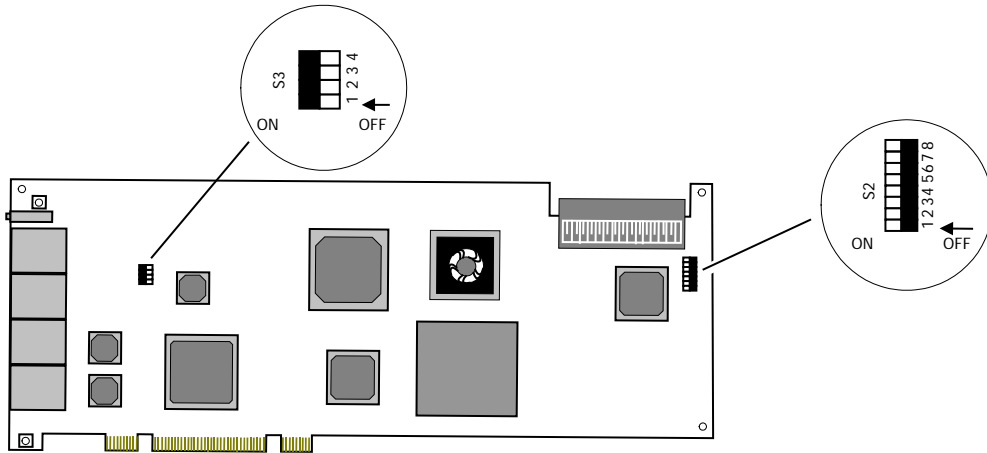

### Configuring SS7 Monitor mode

DIP switch S3 controls the SS7 Monitor mode. By default, all S3 switches are set to the ON position. This setting disables Monitor mode. When Monitor mode is disabled, the TX board is an active participant in the network.

To enable Monitor mode, set all S3 switches to the OFF position. In this mode, the board becomes a passive listening device that monitors network traffic.

### DIP switch S1

DIP switch S1 controls the operation of the board. By default, only switch 2 (AUTOSTART) is set to the ON position; all other S1 switches are set to the OFF position. Switch 5 is reserved for future use. Do not modify the default settings for this switch.

Set switch 8 (SW MIN BOOT) to ON to boot the board to the original software image instead of using the current production software image. This allows for recovery from any condition that resulted in the corruption of the production software image. After setting this switch to ON, use *txreset* to boot the backup software image, and then use *txflash* to burn a clean copy of the production image. Once the production image is completely transferred to the board's flash memory, turn this switch to OFF, and issue *txreset* to boot the board using the newly loaded production software image.

## Installing the board

Complete the following steps to install the TX 4000 board:

1. If necessary, configure the board as described in *Configuring the hardware* on page 6.
2. Power down the computer and disconnect the power cord from the power source. Remove the cover from the computer and set it aside.
3. If you are placing the board into a PCI chassis, remove the PCI retainer bracket by unscrewing it from the board. The bracket is not needed for the board to properly fit into the chassis.

If you are placing the board into an ISA chassis, leave the PCI retainer bracket attached to the board. The bracket is needed for the board to fit properly into the chassis.

4. Remove the blank slot cover from an open PCI bus slot.
5. Arrange the TX 4000 board and other H.100 boards in adjacent PCI bus slots.

Insert the TX 4000 board firmly into the slot. Ensure that the gold-striped edge of the board is seated properly in the expansion slot groove and the bracket of the board is seated in the groove that previously held the slot cover.

6. Align the top of the board bracket with the hole on the top of the expansion slot, and replace the screw that previously held the blank slot cover.
7. Connect the H.100 bus cable to the TX 4000 board.

If you have multiple H.100 boards, connect the H.100 bus cable to each H.100 board.

Verify that the S2 DIP switches are set for H.100 bus termination if the TX 4000 board is installed at either end of the H.100 cable.

8. Replace the cover and connect the computer to the power source.



## Assigning a CP number

Use the *txcpcfg* utility to assign a CP number. Depending on the operating system environment, the *txcpcfg* utility is located in the following directory:

- Windows: *Program Files\Dialogic\tx\bin\*
- UNIX: */opt/dialogic/tx/bin/*

Complete the following steps to assign a CP number:

1. Power up the system if it is not running.  
In a Windows system, the Windows® New Hardware Wizard appears and prompts you for the files required to activate the SS7 drivers. Refer to the *Installing Dialogic® NaturalAccess™ Signaling Software* for detailed information.
2. At the prompt, invoke *txcpcfg* by entering the following command:

```
txcpcfg
```

*txcpcfg* displays the bus number, slot number, CP number, and CP model of boards that are present and configured. Only the bus number, slot number, and CP model identify the board that you are currently configuring. The CP number is undefined.

3. Record the bus and slot values for the undefined TX 4000 board.
4. Assign a unique CP number to each undefined board by entering the following command

```
txcpcfg bus slot unique_CP_number
```

where

- **bus** is the bus number of the TX 4000 board that you are configuring.
  - **slot** is the slot number of the TX 4000 board that you are configuring.
  - **unique\_CP\_number** is a number you assign. Valid CP numbers within the system start at 1 and must be unique. They do not have to be consecutive.
5. Verify the configuration of all of the TX boards by entering the following command:

```
txcpcfg
```

6. Save the configuration changes.  
In a Windows system, configuration changes are saved automatically. In a UNIX system, configuration changes are deleted when you restart the system. Save the changes by editing the *cpcfg* file as described in the *Dialogic® TX 4000 PCI SS7 Network Interface Board Installation Manual*.

## Establishing network connections

Before connecting the board to a network, refer to [www.dialogic.com/declarations/default.htm](http://www.dialogic.com/declarations/default.htm) for information on the current approvals. The trunk connectors and the Ethernet connectors are located on the PCI end bracket as shown in *Interface status LEDs* on page 16.

<p><b>Warning:</b></p> 	<p>Important safety notes for telephony connections:</p> <ul style="list-style-type: none"> <li>• Allow only qualified technical personnel to install this board and the associated telephone wiring.</li> <li>• Make sure the PC chassis is grounded through the power cord or by other means before connecting the telephone line.</li> <li>• If your system requires an external power supply, make sure it is grounded through the power cord or by other means.</li> <li>• Never install telephone wiring during a lightning storm.</li> <li>• Never install telephone jacks in wet locations.</li> </ul> <p>Telephone companies provide primary lightning protection for their telephone lines. However, if a site connects to private lines that leave the building, make sure that external protection is provided.</p>
--	---

### Dialogic® MD1 RJ-45 interface

The TX 4000 provides an Dialogic® MD1 RJ-45 interface to connect to a T1 or E1 network. The following illustration shows the Dialogic® MD1 RJ-45 pinouts:

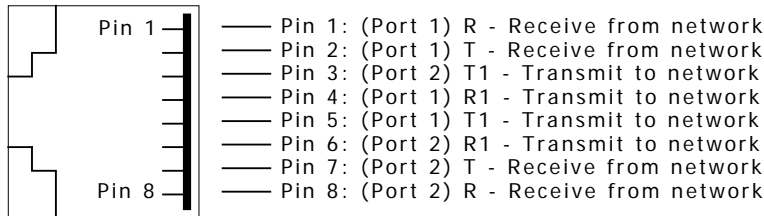

### Ethernet interface

The TX 4000 board has two 10/100Base-T Ethernet interfaces. These interfaces provide Ethernet connections that support auto-negotiation for 100Base-T full duplex/half duplex and 10Base-T full duplex/half duplex transmission. The Ethernet interfaces provide a high-speed interface for connecting a TX 4000 board to either its redundant mate board or to a network of other SIGTRAN devices. Refer to *Connecting TX boards for redundancy* on page 13 for more information.

The following illustration shows the pinouts of the 10/100Base-T Ethernet RJ-45 interfaces:

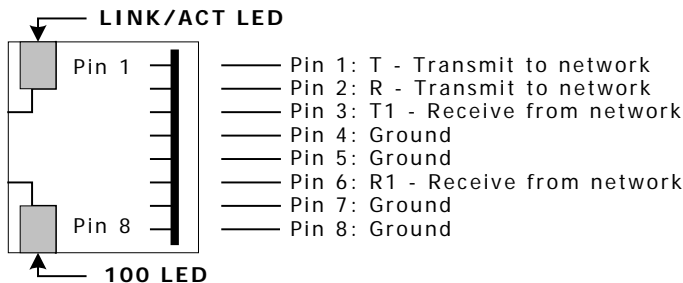

## Connecting to the network

Before connecting a TX 4000 board to the network, ensure that you have properly configured the trunks as either T1 or E1. For configuration information, refer to the *Dialogic® NaturalAccess™ Signaling Software Configuration Manual*.

<b>Caution:</b>	Dialogic obtains board-level approval certificates for supported countries. Some countries require that you obtain system-level approvals for boards connected to the public network. To learn what approvals you require, contact the appropriate regulatory authority in the target country.
-----------------	--

Use a shielded RJ-45 cable to connect a TX 4000 board to a T1 network or to an E1 120 ohm network. Complete the following steps to connect a TX 4000 board to the network:

Step	Action
1	<p>If connecting Trunk 1 or Trunk 2, connect a shielded RJ-45 cable directly to the board.</p> <p>If connecting Trunk 3 or Trunk 4, use dual T1/E1 120 ohm trunk adapter cables to connect to the board. Each trunk adapter cable divides the 8-pin modular jack on the end bracket into two RJ-48C connectors. If you are connecting both jacks, use two cables, otherwise, just use one.</p> <p><b>Note:</b> TX 4000 boards are configured as T1/E1 120 ohm boards. To connect a TX 4000 board as an E1 75 ohm board, use a balun transformer to convert the impedance from 120 ohm to 75 ohm. No other configuration changes are required.</p>
2	Connect shielded RJ-45 cables directly to the trunk connector on the board or to the dual T1/E1 trunk adapter cable. Failure to use a shielded cable may negate your approval.

The following illustration shows the cabling required to connect all four trunks on the TX 4000 board:

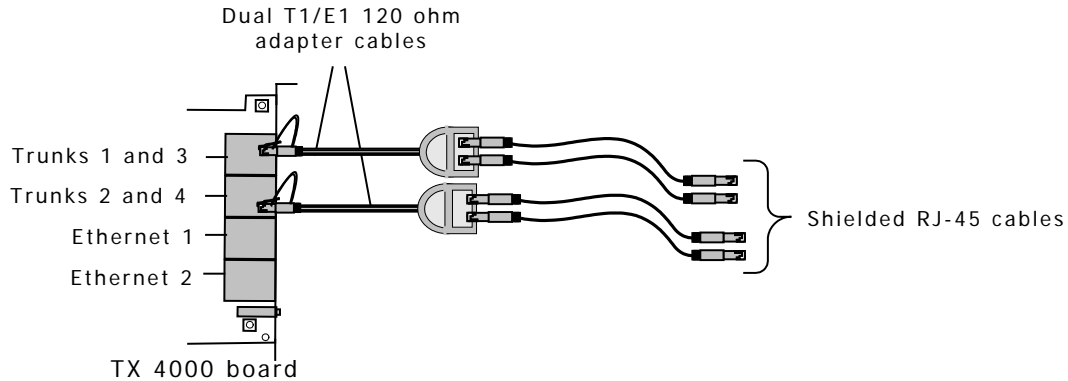

## E1 network considerations

TX 4000 boards can support up to four CEPT E1 trunk interfaces. For typical E1 communications, each E1 interface connects directly to an E1 trunk, as shown in the following illustration:

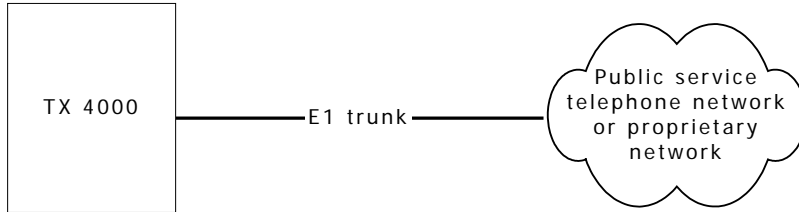

**Note:** Trunks do not synchronize until the board is booted with a valid E1 configuration.

## T1 network considerations

For typical T1 communications, each trunk interface connects to a channel service unit (CSU), which is connected to a T1 trunk line. The CSU provides a DSX-1 interface to the T1 line, and also contains circuitry that enables the central office (CO) to perform diagnostic tests remotely. The following illustration shows the TX 4000 trunk interface with CSU:

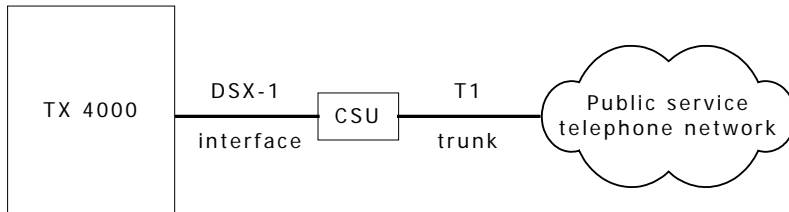

**Note:** Trunks do not synchronize until the board is booted with a valid T1 configuration.

You can purchase or lease the CSU from the telephone company or other vendor.

**Warning:**



**Important safety notes for telephony connections:**

Use a channel service unit (CSU) to isolate the cables that are attached to this product before the cables leave the building.

To avoid causing T1 service provider alarms, make sure that the board always sends a valid signal, either by looping back at the CSU or by connecting the CSU to a functioning TX 4000 board. The best way to provide a loopback is to unplug the cable from the TX board to the CSU. The modular connector on most CSUs loops back the transmit signal to the receive signal when nothing is plugged in.

For information on the cable requirements depending on the target country and network type, refer to [www.dialogic.com/declarations/default.htm](http://www.dialogic.com/declarations/default.htm).

## Connecting TX boards for redundancy

Use the redundancy feature to enable the system to detect and recover from the failure of signaling links on a TX 4000 board, the failure of a signaling node, or the failure of the TX 4000 board itself.

In a redundant configuration, each pair of TX boards is connected through a private Ethernet connection. If other devices are connected to the private Ethernet link, avoid overloading the link. Packets can be lost between the redundant TX boards if the connection is overloaded.

This topic describes dual-node redundant signaling and single-node redundant signaling for the following types of configurations:

- TDM configuration
- IP network configuration

### TDM configuration

To connect a TX 4000 board to its redundant mate in a TDM configuration, use a Category 5 shielded twisted pair (STP) crossover cable. With the crossover cable, connect Ethernet 1 on the primary board to Ethernet 1 on the backup board.

You must specify the IP address of the TX boards redundant mate using the mate command in the *txconfig* utility. You must also specify the IP address and network mask of Ethernet interface 1 using the *ifcreate* command in the *txconfig* utility. For more information, refer to the *Dialogic® NaturalAccess™ Signaling Software Configuration Manual*.

### Dual-node redundant signaling server

The following illustration shows how to set up two TX 4000 boards based on a dual-node redundant signaling server in a TDM configuration. The boards are located in two separate chassis to ensure board-level and system-level redundancy.

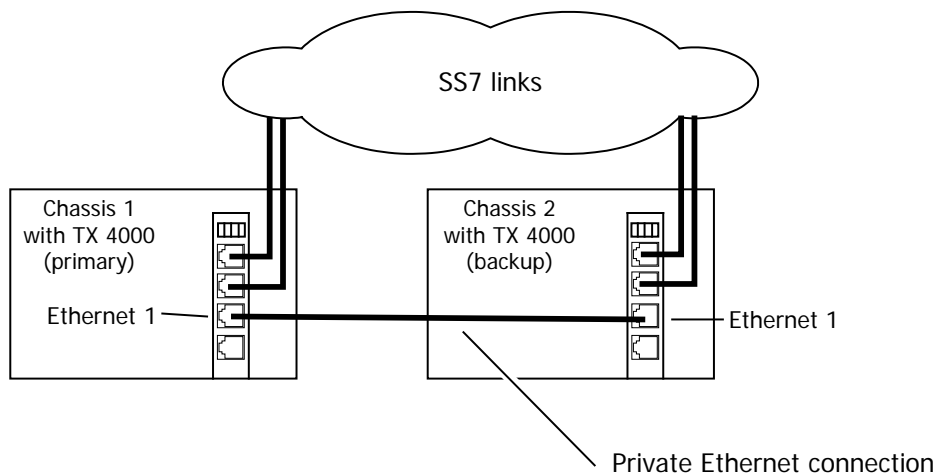

## Single-node redundant signaling server

The following illustration shows how to set up two TX 4000 boards based on the single-node signaling server in a TDM configuration. The boards are located in the same chassis to ensure board-level redundancy.

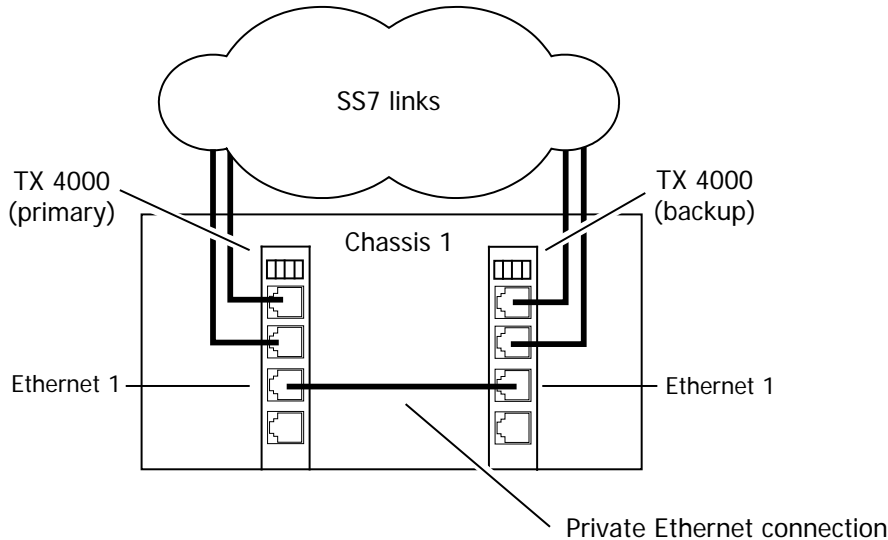

## IP network configuration

To connect a TX 4000 board to its redundant mate in an IP network configuration, use a Category 5 shielded twisted pair (STP) crossover cable. Using the crossover cable, connect Ethernet 1 on the primary board to Ethernet 1 on the backup board. Using standard Ethernet cables, connect the Ethernet 2 connectors on both boards to the IP network connectors.

**Note:** Dialogic recommends using a private Ethernet link to connect the redundant boards to avoid loss or delay of vital checkpoint messages. However, if each board in the redundant pair requires multi-homing, you can use Ethernet 1 for both the redundant pathway and for SIGTRAN network access. In this configuration, the Ethernet 1 on each board is connected to what is shown as an IP network cloud in the illustrations that follow (just as the Ethernet 2 connectors are). Be aware that this greatly increases the chance of lost or delayed checkpoint messages which can result in the backup having outdated information.

You must specify the IP address of the TX boards redundant mate using the mate command in the *txconfig* utility. You must also specify the IP address and network mask of Ethernet interface 1 using the *ifcreate* command in the *txconfig* utility. For more information, refer to the *Dialogic® NaturalAccess™ Signaling Software Configuration Manual*.

### Dual-node redundant signaling server

The following illustration shows how to set up two TX 4000 boards based on a dual-node redundant signaling server in an IP network configuration. The boards are located in two separate chassis to ensure board-level and system-level redundancy.

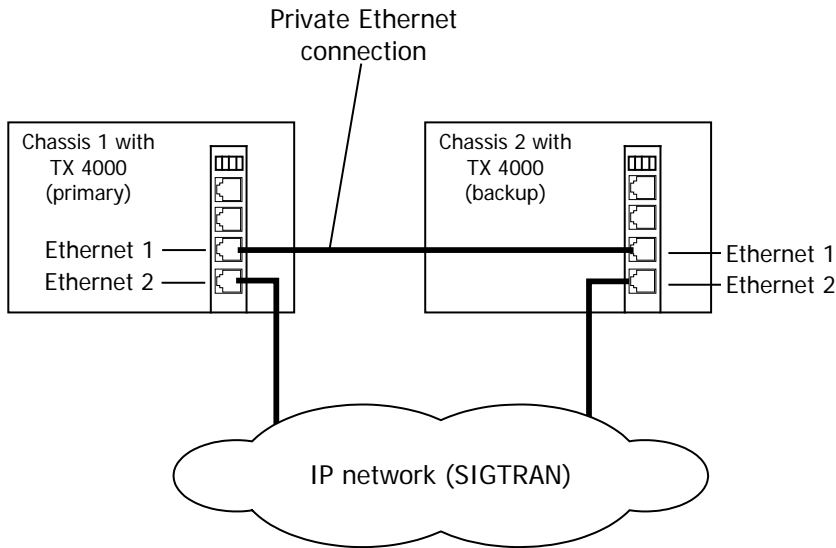

### Single-node redundant signaling server

The following illustration shows how to set up two TX 4000 boards based on a single-node signaling server in an IP network configuration. The boards are located in the same chassis to ensure board-level redundancy.

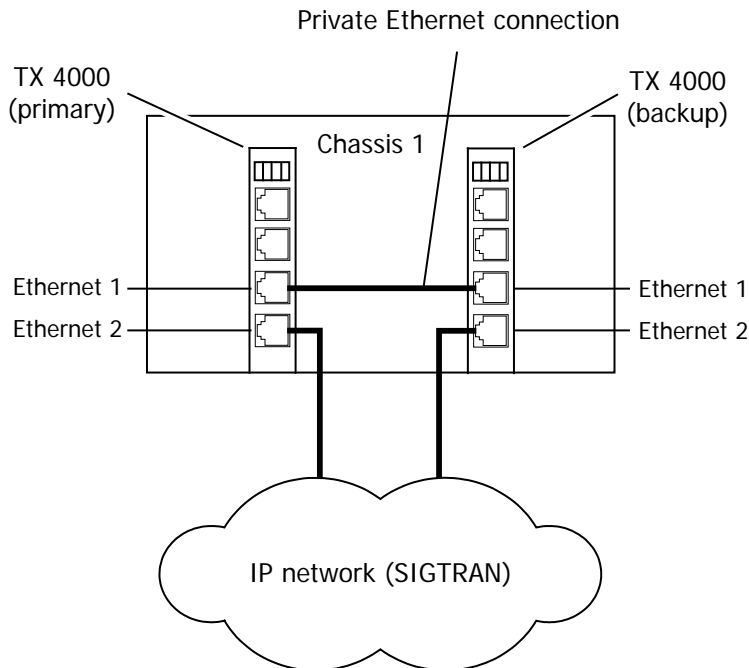

For more information on SS7 redundancy, refer to the *Dialogic® TX Series SS7 Boards Health Management Developer's Reference Manual*.

## Interface status LEDs

The TX 4000 board provides LEDs to indicate the status of the trunk and Ethernet interfaces. The location of the LEDs is shown in the following illustration:

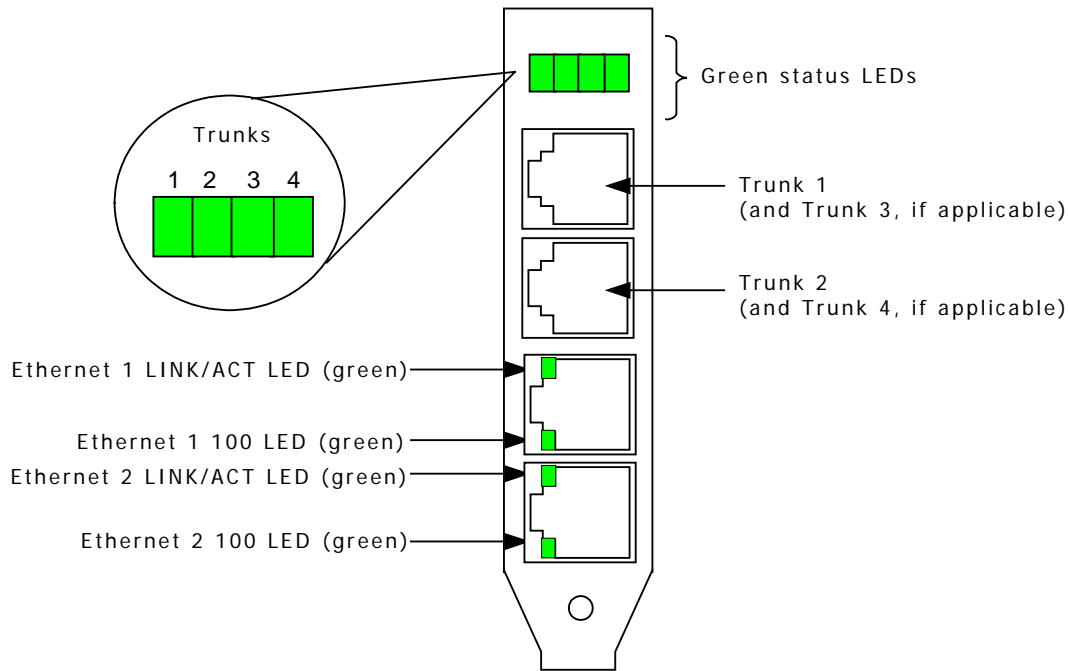

## Trunk LEDs

The TX 4000 board has one green LED for each trunk interface. The trunk LEDs provide the following indications:

Trunk LED	Description
Off	Trunk has not been configured.
Slow blinking green	Indicates loss of signal.
Fast blinking green	Indicates loss of frame or loss of signaling multiframe.
Steady green	Indicates that proper frame synchronization between the trunk and network has been established. All required framing alignment has been found.

## Ethernet LEDs

The TX 4000 board provides two LEDs to indicate the status of each Ethernet interface. The following table describes the functionality of each Ethernet LED:

Ethernet LED	Description
LINK/ACT	Indicates the status of the Ethernet link. When the Ethernet link has established link integrity, the LED is on and steady. It also indicates the transmitting and receiving activity on the link. When activity is present on the Ethernet link, the LED flickers.
100	Indicates the data rate of the Ethernet link. When the LED is on, the data rate is 100 Mb. When the LED is off, the data rate is 10 Mb. The LED is used only when a reliable Ethernet connection has been established. (The LINK/ACT LED is on.)



## Board status LEDs

On the back of the TX 4000 board, banks of LEDs (D6-D21) indicate the current status of the board. The following illustration shows the board status LEDs:

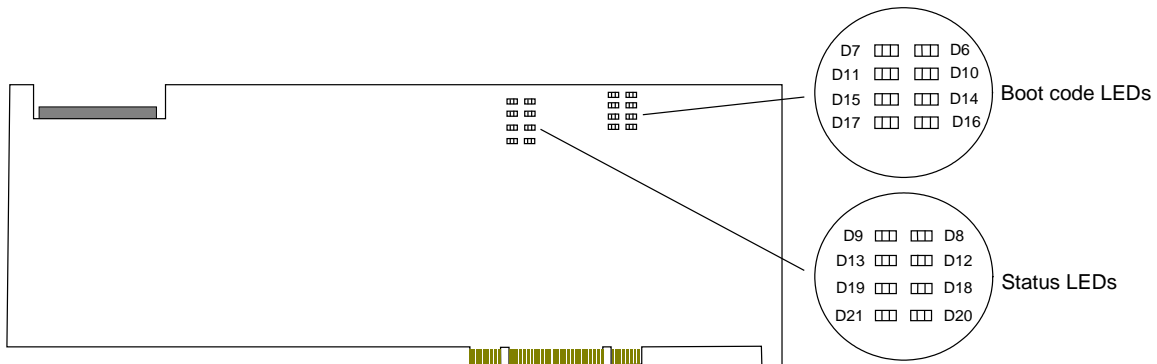

### Boot code LEDs

Boot code LEDs are active when the TX 4000 board is powered up. These LEDs progress through a series of red codes. If the power up is successful, these LEDs turn green. If no LEDs illuminate, the voltage level may be too low, or the power supply may not be providing enough 3.3 V or 5 V current to power up the TX 4000 board.

### Status LEDs

After the boot code LEDs turn green, the status LEDs are active and indicate the current board status:

LED	Color	Status when illuminated
D8	Green	Timer interrupt controlled heartbeat. The LED flickers to indicate that the timer interrupts are operating properly.
D9	Green	Idle task controlled heartbeat. The LED flickers to indicate that the on-board operating system is operational.
D12	Red	Board is executing in snapshot mode: the board is resetting or <i>txsnap</i> is running. For more information on <i>txsnap</i> , refer to the <i>Dialogic® TX Series SS7 Boards TX Utilities Manual</i> .
D13	-----	Reserved for internal use.
D18	Red	Kernel detected a host communication error.
D19	Red	Memory full condition occurred on the board.
D20	Red	Unexpected exception occurred on the board.
D21		Kernel detected a problem. Use the <i>cpcon</i> utility's log command to view error information. For more information on <i>cpcon</i> , refer to the <i>Dialogic® TX Series SS7 Boards TX Utilities Manual</i> .

## Compliance statements

### EU R&TTE statement

This product is intended to be connected to a 2048 kbit/s 75 ohm or 120 ohm digital structured or unstructured ONP leased line in all EU countries. For more information, refer to [www.dialogic.com/declarations/default.htm](http://www.dialogic.com/declarations/default.htm).

### FCC Part 15 Class A statement

This board has been tested and found to comply with the limits for a Class A digital device, pursuant to Part 15 of the FCC Rules. These limits are designed to provide reasonable protection against harmful interference when the equipment is operated in a commercial environment. This equipment generates, uses and can radiate radio frequency energy and, if not installed and used in accordance with the instruction manual, may cause harmful interference to radio communications. Operation of this equipment in a residential area is likely to cause harmful interference, in which case the user will be required to correct the interference at his or her own expense. Modifications not expressly approved by Dialogic may void the FCC granted authority to operate the equipment.

### FCC Part 68 statement

This equipment complies with Part 68 of the FCC rules and the requirements adopted by the ACTA. On the bottom of this equipment is a label that contains, among other information, a product identifier in the format US:EMCXDNANXXXXXXXXX. If requested, this number must be provided to the telephone company.

The telephone company will need to know the Service Order Code, the Facility Interface Code, and the wiring configuration (or USOC jack type) corresponding to the service you are ordering, as shown in this table:

Service type	Facility interface code	Service order code	USOC jack
4-wire 1.544 Mbps (DS1) with Super Frame (SF), Alternate Mark Inversion ("AMI"), no line power, 100 ohms.	04DU9-BN	6.0N	RJ-48C
4-wire 1.544 Mbps (DS1) with SF, Bipolar with eight-zero substitution (B8ZS), no line power, 100 ohms.	04DU9-DN	6.0N	RJ-48C
4-wire 1.544 Mbps (DS1) with Extended Super Frame (ESF), AMI, no line power, 100 ohms.	04DU9-1KN	6.0N	RJ-48C
4-wire 1.544 Mbps (DS1) with ESF, Bipolar with Eight-Zero Substitution ("B8ZS"), no line power, 100 ohms.	04DU9-1SN	6.0N	RJ-48C

If this equipment causes harm to the telephone network, the telephone company will notify you in advance that temporary discontinuance of service may be required. But if advance notice isn't practical, the telephone company will notify you as soon as possible. Also, you will be advised of your right to file a complaint with the FCC if you believe it is necessary.

The telephone company may make changes in its facilities, equipment, operations or procedures that could affect the operation of the equipment. If this happens the telephone company will provide advance notice in order for you to make necessary modifications to maintain uninterrupted service.

This product is not intended for customer repair.

### Canadian ICES-003 statement

This Class A digital apparatus complies with Canadian ICES-003. Cet appareil numérique de la classe A est conforme à la norme NMB-003 du Canada.

### CS-03 statement

This product meets the applicable Industry Canada technical specifications. Le présent matériel est conforme aux spécifications techniques applicables d'Industrie Canada.

**Caution:** Users should not attempt to make such connections themselves, but should contact the appropriate electric inspection authority or electrician.

## Europe

### CE Compliance

The Dialogic® products covered by this notice meet the following European Directives:

2006/95/EC	Safety/Low Voltage Directive
2004/108/EC	EMC Directive
99/05/EC	R&TTE Directive

To achieve CE compliance, be sure to select a host that already meets the EMC and Low Voltage Directives before the addition of any optional board. Remember that the use of option boards declared compliant with the Directives by their manufacturer only gives "presumption of compliance" for the whole system. It is the responsibility of the system supplier to verify that the requirements of the listed Directives are still met by the final system, as supplied to the end-user. System integrators should take notice of further conditions expressed in this section and the Safety section.

The products covered by this notice have been successfully tested against TBR 4 basic call control. Application developers implementing supplementary services at application level must ensure that their implementation complies with the services offered by the local Public Switched Telephone Network (PSTN) operator. In case of doubt, network specifications must be consulted; the R&TTE Directive imposes that each PSTN operator makes such specifications available.

Inter-working is guaranteed only with Public Switched Telephone Networks (PSTNs) offering Primary Rate Access conforming to EuroISDN specifications.

Before any connection to PSTN offering Primary Rate Access to other national or international E1 standards, please consult your Dialogic representative.

## Compliance with the R&TTE Directive

The R&TTE Directive includes its own safety and EMC requirements. Although equipment declared compliant to the R&TTE Directive does not require explicit declaration of conformity to EMC and Low Voltage Directives, the above conditions must also be met to satisfy the safety and EMC requirements of the R&TTE Directive.

Inter-working is guaranteed only with Public Switched Telephone Networks (PSTNs) as described in the sections above.

Dialogic Declarations of Conformity for these products can be found at:  
<http://www.dialogic.com/declarations/>

Manufacturer's office in European Union:

Dialogic Distribution Limited  
Unit 4034  
Citywest Business Campus  
Saggart, Co. Dublin  
IRELAND

Tel: +353 1 630 9000

Fax: +353 1 630 9099

Hereby, Dialogic Corporation, declares that this equipment is in compliance with the essential requirements and other relevant provisions of European Union Directives 1999/5/EC (R&TTE), 2004/108/EC (EMC Directive) and 2006/95/EC (Low Voltage Directive).

### [Česky]

Dialogic Corporation tímto prohlašuje, že tento ITE je ve shodě se základními požadavky a dalšími příslušnými ustanoveními směrnice 1999/5/ES, 2004/108/ES, 2006/95/ES.

### [Dansk]

Undertegnede Dialogic Corporation erklærer herved, at følgende udstyr ITE overholder de væsentlige krav og øvrige relevante krav i direktiv 1999/5/EF, 2004/108/EF, 2006/95/EF.

### [Deutsch]

Hiermit erklärt Dialogic Corporation, dass sich das Gerät ITE in Übereinstimmung mit den grundlegenden Anforderungen und den übrigen einschlägigen Bestimmungen der Richtlinie 1999/5/EG, 2004/108/EG, 2006/95/EG befindet.

### [Eesti]

Käesolevaga kinnitab Dialogic Corporation seadme ITE vastavust direktiivi 1999/5/EÜ, 2004/108/EÜ, 2006/95/EÜ, põhinõuetele ja nimetatud direktiivist tulenevatele teistele asjakohastele sätetele.

### [Español]

Por medio de la presente Dialogic Corporation declara que el ITE cumple con los requisitos esenciales y cualesquiera otras disposiciones aplicables o exigibles de la Directiva 1999/5/CE, 2004/108/CE, 2006/95/CE.

### **[Ελληνική]**

ΜΕ ΤΗΝ ΠΑΡΟΥΣΑ Dialogic Corporation ΔΗΛΩΝΕΙ ΟΤΙ ΙΤΕ ΣΥΜΜΟΡΦΩΝΕΤΑΙ ΠΡΟΣ ΤΙΣ ΟΥΣΙΩΔΕΙΣ ΑΠΑΙΤΗΣΕΙΣ ΚΑΙ ΤΙΣ ΛΟΙΠΕΣ ΣΧΕΤΙΚΕΣ ΔΙΑΤΑΞΕΙΣ ΤΗΣ ΟΔΗΓΙΑΣ 1999/5/ΕΚ, 2004/108/ΕΚ, 2006/95/ΕΚ.

### **[Français]**

Par la présente Dialogic Corporation déclare que l'appareil ITE est conforme aux exigences essentielles et aux autres dispositions pertinentes de la directive 1999/5/CE, 2004/108/CE, 2006/95/CE.

### **[Italiano]**

Con la presente Dialogic Corporation dichiara che questo ITE è conforme ai requisiti essenziali ed alle altre disposizioni pertinenti stabilite dalla direttiva 1999/5/CE, 2004/108/CE, 2006/95/CE.

### **[Latviski]**

Ar ao Dialogic Corporation deklarē, ka ITE atbilst Direktīvas 1999/5/EK, 2004/108/EK, 2006/95/EK būtiskajām prasībām un citiem ar to saistītajiem noteikumiem.

### **[Lietuvių]**

Šiuo Dialogic Corporation deklaruoja, kad ais ITE atitinka esminius reikalavimus ir kitas 1999/5/EB, 2004/108/EB, 2006/95/EB, Direktyvos nuostatas.

### **[Magyar]**

Alulírott, Dialogic Corporation nyilatkozom, hogy a ITE megfelel a vonatkozó alapvető követelményeknek és az 1999/5/EK, 2004/108/EK, 2006/95/EK, irányelv egyéb előírásainak.

### **[Malti]**

Hawnhekk, Dialogic Corporation, jiddikjara li dan ITE jikkonforma mal-h- tig- jiet essenzjali u ma provvedimenti oh- rajn rilevanti li hemm fid-Direttiva 1999/5/KE, 2004/108/KE, 2006/95/KE.

### **[Nederlands]**

Hierbij verklaart Dialogic Corporation dat het toestel ITE in overeenstemming is met de essentiële eisen en de andere relevante bepalingen van richtlijn 1999/5/EG, 2004/108/EG, 2006/95/EG.

### **[Polski]**

Niniejszym, Dialogic Corporation, oświadcza, że ITE jest zgodny z zasadniczymi wymogami oraz pozostałymi stosownymi postanowieniami Dyrektywy 1999/5/WE, 2004/108/WE, 2006/95/WE.

### **[Português]**

Dialogic Corporation declara que este ITE está conforme com os requisitos essenciais e outras disposições da Directiva 1999/5/CE, 2004/108/CE, 2006/95/CE.

### [Slovensko]

Dialogic Corporation izjavlja, da je ta ITE v skladu z bistvenimi zahtevami in ostalimi relevantnimi določili direktive 1999/5/ES, 2004/108/ES, 2006/95/ES.

### [Slovensky]

Dialogic Corporation týmto vyhlasuje, že ITE spĺňa základné požiadavky a vetyky prislúšané ustanovenia Smernice 1999/5/ES, 2004/108/ES, 2006/95/ES.

### [Suomi]

Dialogic Corporation vakuuttaa täten että ITE tyyppinen laite on direktiivin 1999/5/EY, 2004/108/EY, 2006/95/EY oleellisten vaatimusten ja sitä koskevien direktiivin muiden ehtojen mukainen.

### [Svenska]

Härmed intygar Dialogic Corporation att denna ITE står i överensstämmelse med de väsentliga egenskapskrav och övriga relevanta bestämmelser som framgår av direktiv 1999/5/EG, 2004/108/EG, 2006/95/EG.

### [Íslenska]

Hér með lýsir Dialogic Corporation yfir því að ITE er í samræmi við grunnkröfur og aðrar kröfur, sem gerðar eru í tilskipun 1999/5/EC, 2004/108/EC, 2006/95/EC.

### [Norsk]

Dialogic Corporation erklærer herved at utstyret ITE er i samsvar med de grunnleggende krav og øvrige relevante krav i direktiv 1999/5/EF, 2004/108/EF, 2006/95/EF.

## Australia

Dialogic is required to provide the following information as a condition of the telecommunications conformity of Dialogic® telecommunications products. You may also be responsible for meeting requirements other than those outlined in this document.

**Note:** Failure to meet the requirements listed may render the products non-compliant, with the user liable to significant penalties under the Telecommunications Act.

Do not connect these products directly to a telecommunications network. These products must be connected to a network terminating unit (NTU) or some other device that provides line isolation. This allows the carrier's telecommunications network to be electrically isolated from the product and host PC.

These products are only to be connected to safety extra low voltage circuits. These products should only be connected to the safety extra low voltage (SELV) port of the network termination unit (NTU) or PBX that is providing the E-1 interface.

## South Korea

명 칭 ( 모 델 명 ) : TX4000

인 증 번 호 : TE-A62/K900-04-0324

인증받은자의 상호 : Dialogic Corporation

제 조 년 월 일 : Marked on serial number tag

제 조 자 / 제 조 국 : Made in USA

## Class A statement

This Class A digital apparatus meets all requirements of the Korean EMI regulations.

A급 기기 (업무용 방송통신기기)

이 기기는 업무용(A급)으로 전자파적합등록을 한 기기이오니 판매자 또는 사용자는 이 점을 주의하시기  
바라며, 가정외의 지역에서 사용하는 것을 목적으로 합니다.

Telecom regulatory approval of this product is conditional upon the use of suitable surge suppressors on the E1 interface port(s). The approved 4-wire E1 surge protector is available from Dialogic as part number 83294 or from Patton Electronics, part number 552-T1 ([www.patton.com](http://www.patton.com)).

## China

### **对中国电子信息产品污染控制管理办法的认证** **Compliance to China ROHS Requirements**

1. **中国电子信息产品中有毒有害物质的限量要求** – 标准#SJ/T 11363-2006.  
**China ROHS Limits** – Standard# SJ/T 11363-2006.

此产品符合中国电子信息产品有毒有害物质的限量要求。

This product is below all hazardous substance limits of the above China ROHS standard.

2. **中国电子信息产品污染控制标识要求**– 标准#SJ/T 11364-2006.  
**China ROHS Markings** – Standard# SJ/T 11364-2006.

以下污染控制标识表示此产品符合有毒有害物质的限量要求。

The pollution control label below states that this product is below all hazardous substance limits.



3. **中国电子信息产品包装回收标识** -标准#GB 18455-2001.  
**China ROHS Packaging Recycling Marks** – Standard# GB 18455-2001.





**电子信息产品污染控制表格**  
**Restriction of Hazardous Substance Table (HST)**

型号 MMG Model MMG		O = 在 RoHS 限制之内 O = Within ROHS concentration limits for this substance				
		X = 不在 RoHS 限制之内 X = Exceeds ROHS concentration limits for this substance				
产品 Part	铅 Lead (Pb)	汞 Mercury (Hg)	镉 Cadmium (Cd)	六价铬 Chromium (Cr)	多溴联苯 PolyBrom. (PBB)	多溴二苯醚 PolyBrom. (PBDE)
所有 (金属) All (Metals)	X	O	O	O	O	O
电路板 Circuit Boards	X	O	O	O	O	O
聚合物件 Polymer Parts	X	O	O	O	O	O
电缆和电缆 Wiring and Cables	X	O	O	O	O	O
其他部分 Components	X	O	O	O	O	O

## Product declarations and global approvals

For information about product declarations and global approvals, refer to [www.dialogic.com/declarations/default.htm](http://www.dialogic.com/declarations/default.htm).

## RoHS Statement

For information about RoHS compliance for this product, refer to [www.dialogic.com/rohs/default.htm](http://www.dialogic.com/rohs/default.htm).

## Product environmental information

During August 2005, the European Union Directive on Waste Electrical and Electronic Equipment (2002/96/EC) and its amendment (2003/108/EC), collectively known as the WEEE Directive, came into force throughout most of the European Union. This Dialogic® product comes within the scope of the WEEE Directive. We are confident that this product will provide you with many years of reliable service.

Moreover, we are pleased to advise you that Dialogic warrants this product, as detailed in the user guide and provides a fee based repair service when the product is out of warranty. However, a time will come when the product will no longer meet your needs or will become un-economic to repair. It is at that stage that we ask for your co-operation in recycling this product in the spirit of the WEEE directive.

Dialogic has taken great care to minimize the environmental burden of this product by careful design and manufacturing it under an Environmental Management System, registered to ISO14001. The requirements of ISO14001 are similar to and as rigorous as the requirements of ISO9001, Quality Management Systems with which you may be more familiar. We ask you to help us to ensure that the environmental burden of this product is minimized when it is of no further use to you by recycling it. Please do not dispose of this product through municipal or general waste systems because it contains materials which can be economically recycled. Like all electrical and electronic equipment, including televisions and computers, it may contain small amounts of materials which could lead to environmental damage. To minimize any environmental damage we ask you to have this product recycled by:

- Bringing it to the recycling collection point in your company
- Handing it into the store where you are purchasing the replacement
- Delivering it to a local bring-centre in your area

No charge can be imposed on you for this recycling service, in the European Union, as Dialogic has paid for recycling this product when it was placed on the market. These are requirements of the WEEE directive. We thank you in advance for your co-operation and working with Dialogic in protecting our environment.



■ Please do not dispose of this product through municipal or general waste, recycle it.

## Limited warranty

For warranty information, refer to [www.dialogic.com/warranties](http://www.dialogic.com/warranties).